

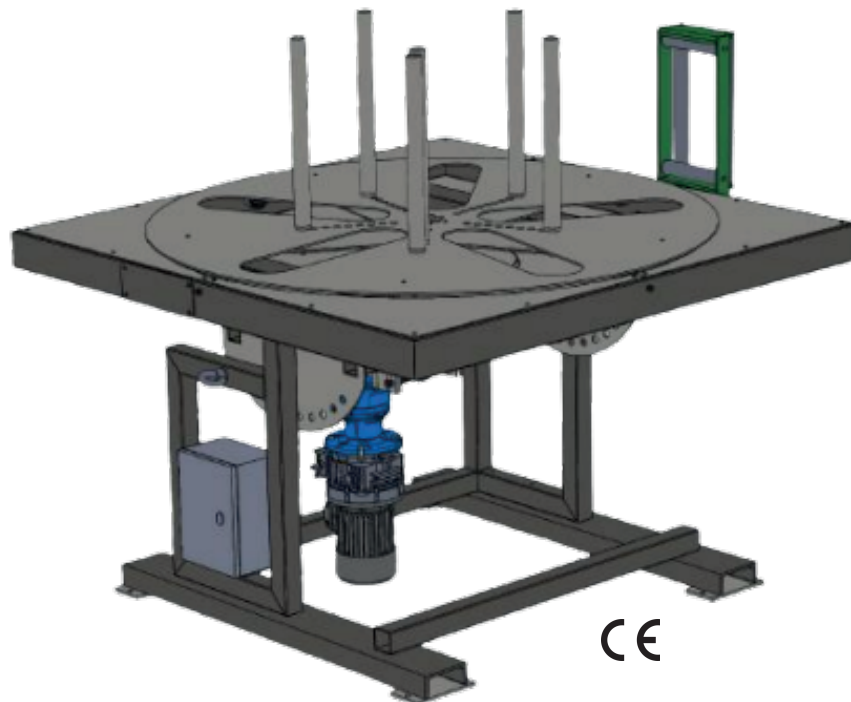

HOSE CUTTING SOLUTIONS

MOTORIZED COILER TYPE DM424

Adapted for coiling flexible hoses (can also uncoil)



TECHNICAL SPECIFICATIONS

- Solid 4-legged frame for easy handling and fixing to the floor
- Adjustable working position from 0° to 90°
- The coil diameter varies according to the different models of crowns (from 250 to 720mm)
- Pedal operated
- Equipped with a 1.1kW three phases geared motor
- Power supply: 400V TRI
- Maximum coiler speed : from 4 to 24 rpm
- Working height: 1010mm
- Allowable load on the tray: 400kg
- Dimensions: H x W x L : 1500 x 1600 x 1600mm
- Weight: 350kg



ETS CLAVEL - 5 Rue Pierre et Marie Curie, 18520 AVORD - France
<https://www.clavel.fr> Tel : 02 48 76 80 14 contact@clavel.fr

