

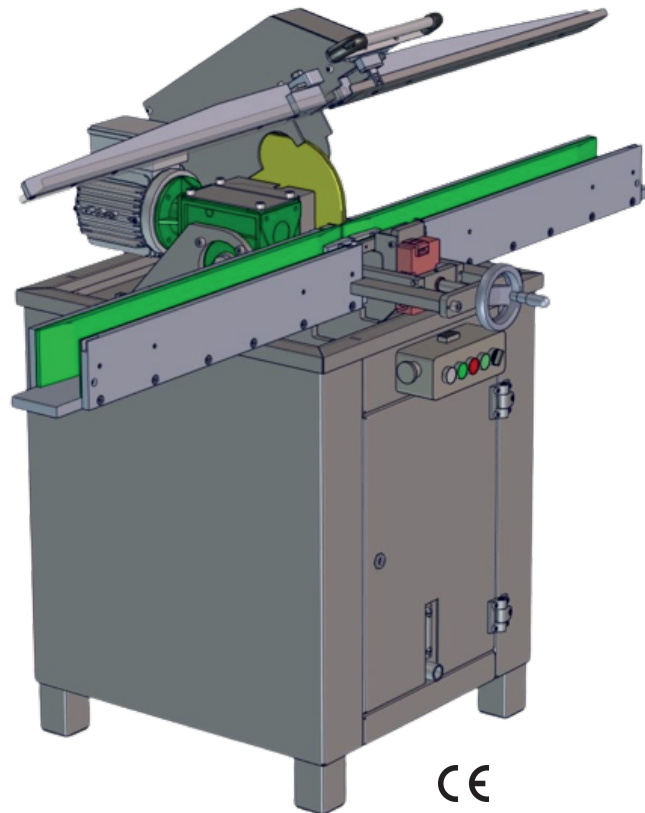

**HOSE CUTTING SOLUTIONS**

## **GUILLOTINE GM135**

To cut rubber hoses



### **TECHNICAL SPECIFICATIONS**

- Capacity: 80 mm
- Cutting operation with a rotating blade type « SNAIL »
- Blade driven by a 1.5 kW geared motor
- Working height: 1000mm
- Floor-mounted model
- Lubrication of both sides of the cutting blade
- Equipped with a safety cover
- Dual control
- Power supply: 400V Tri - 50Hz
- Dimensions: H x l x L : 1404 x 1803 x 943mm  
Weight: 250kg



**ETS CLAVEL - 5 Rue Pierre et Marie Curie, 18520 AVORD - France**  
<https://www.clavel.fr> Tel : 02 48 76 80 14 contact@clavel.fr

