

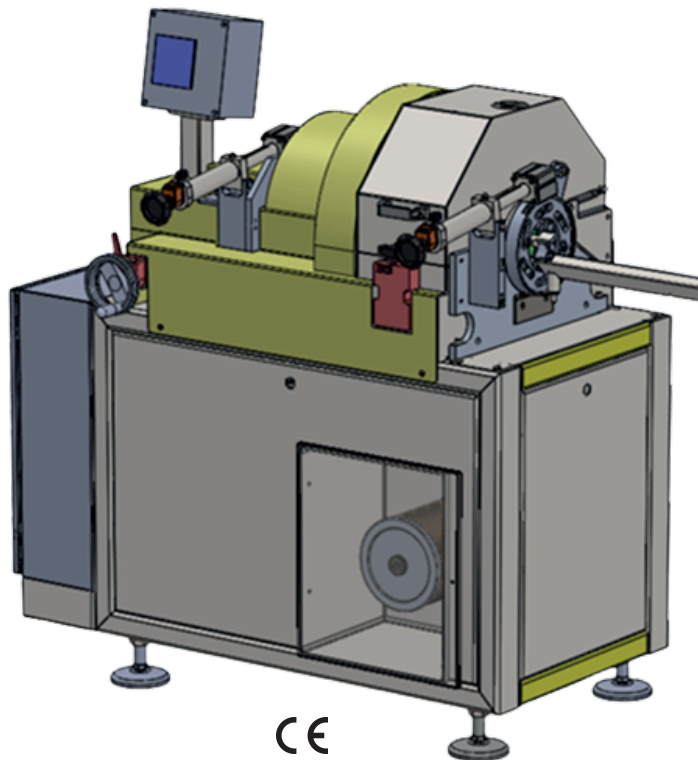

**HOSE CUTTING SOLUTIONS**

## **PLANETARY CUTTING MACHINE TYPE TP75**

Semi-automatic Cutter for Metal Corrugated Hoses  
with one Wire Braid Capacity :2"



### **TECHNICAL SPECIFICATIONS**

- Bench mounted machine to cut hoses piece by piece or in batches
- Semi-automatic process
- Preset of internal diameter by counter
- Preset of cut quantity, blade turns on display
- Incorporated powerful vacuum cleaner
- Connection nozzle with aspiration system
- Power supply: 400V TRI - 50Hz
- Option: Measuring bar up to 1.000 m for batch cutting with hard stop
- Dimensions: H x W x L : 1560 x 1720 x 5820mm
- Weight: 490kg



**ETS CLAVEL - 5 Rue Pierre et Marie Curie, 18520 AVORD - France**  
<https://www.clavel.fr> Tel : 02 48 76 80 14 [contact@clavel.fr](mailto:contact@clavel.fr)

